

Trentino Networking Testbed for the Future Internet



UNIVERSITY OF TRENTO - Italy

Satisfying “Global Triple-Any”: Anything at Anytime for Anyone

Prof. Renato Lo Cigno – University of Trento – Italy

locigno@dit.unitn.it

<http://dit.unitn.it/locigno/>

FIRE: Future Internet Research and Experimentation
Scientific and Industrial Preparatory Group Meetings
ETH – Zurich March 6-7, 2007

Motivations

Two primary Internet transitions:

- From **business** to **home (mobile) users**
 - The capacity per home will equal campus capacity
- From **broadcast** to **on-demand**:
 - Triple-any: **anyone/anything/anytime**
 - Global scale: **from anywhere to anywhere**

■ **Traffic will increase 10-50 folds.**

■ **>90% of traffic will be to home users.**

■ **Business Model is a central issue**

Motivations

- Development requires experiment and data to evolve
- Experiment must exit the labs
- Internet-based experimentation is fine BUT:
 - Does not allow “new paradigm” investigation
 - Does not support technological jumps
- **Need large scale experimental networks**

Initial Testbed Layout

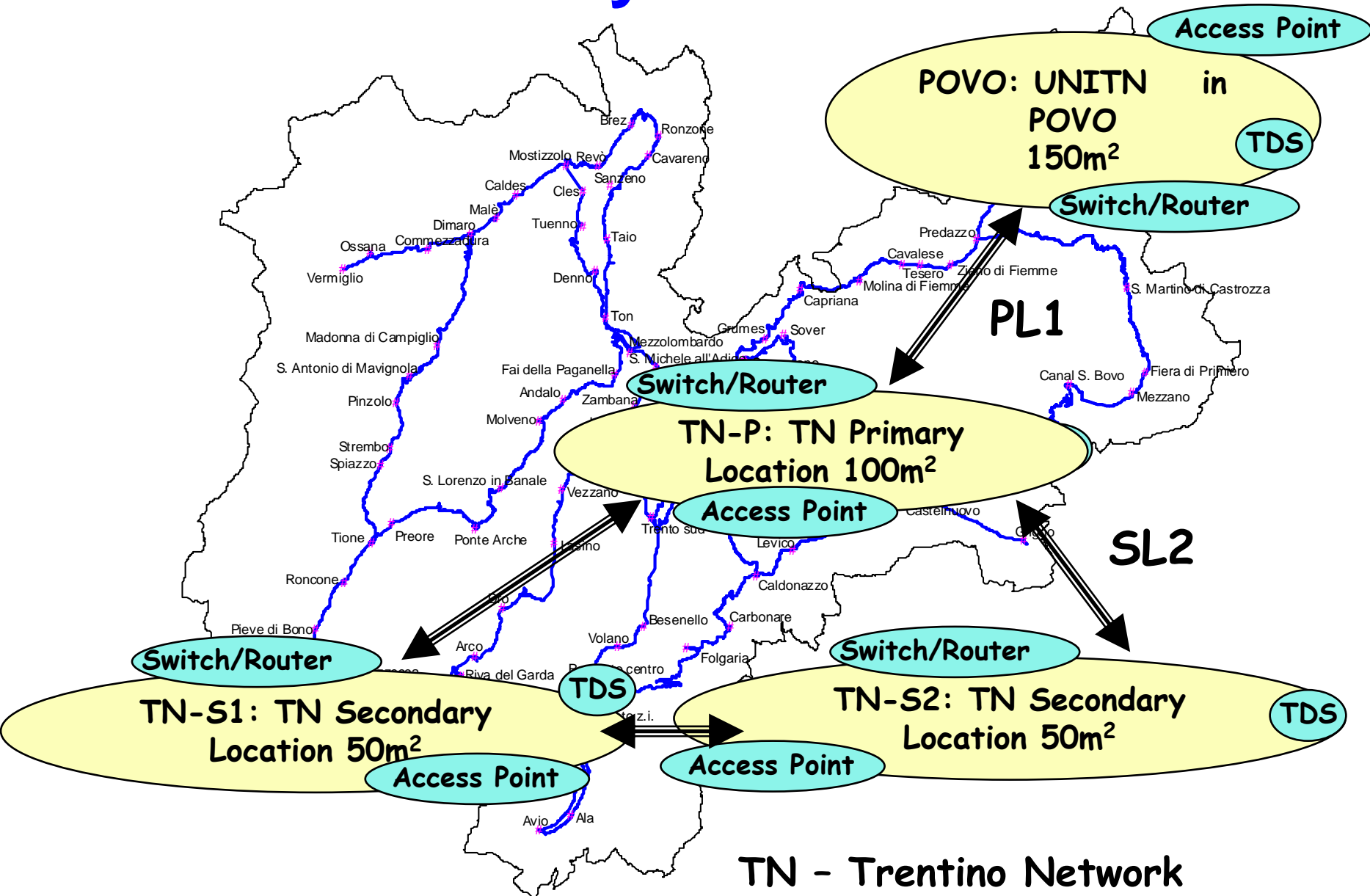

TN - Trentino Network

Initial Testbed Layout

Dual-networks: (i) Experimental & (ii) Production

O-TDS: All Optical Time-driven Switch

L2-SW: Layer 2 Switch

L3-SW: Layer 3 Switch

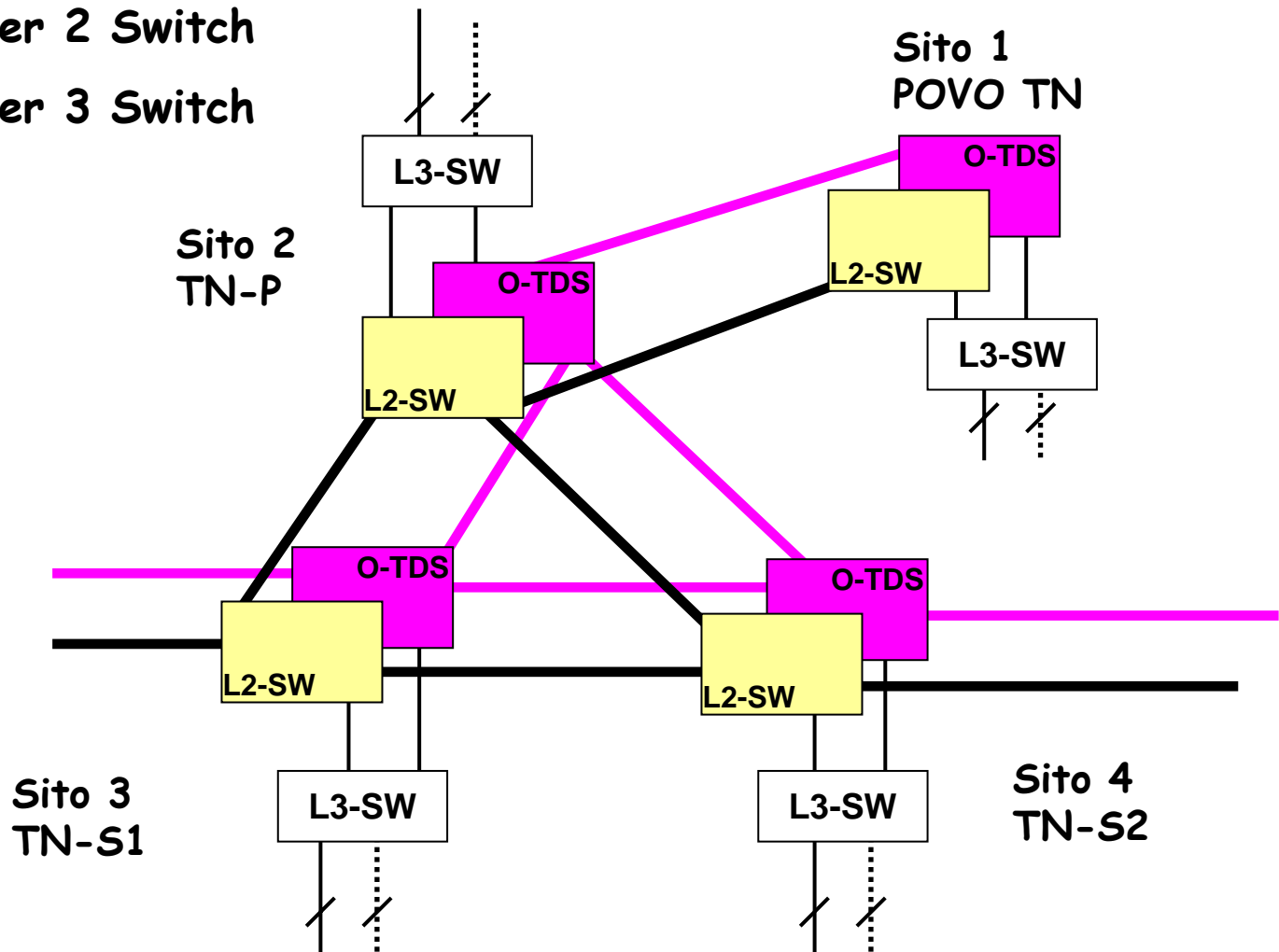

Initial Testbed Layout

- 800 km 2 pairs of “dark-fiber” along the Trentino Network
- Full access to customers for wide scale business experiments
- Full roaming access to the Wireless Local Loop & Nomadic (802.11—802.16) network under construction
- 6-12 yrs project for future Internet:
 - technologies
 - applications
 - services
- Additional initial fundign af ~1Meuro from PAT (under negotiation)
- Continues EU funded IP-FLOW project
<http://dit.unitn.it/ip-flow>
- Open to EU projects and not only

Summary

- Initial funding of 1 million Euros from PAT (under discussion)
- Motivations: Internet will burst with on-demand traffic
 - **Framework for global triple-any (Anyone/Anything/Anytime)**
- Opportunities for new technological solutions and new services
 - **Real testing over 800 km optical network**
 - **Interconnection with Wireless access and final users**
 - **Potential spin-offs and joint ventures**
- Initial structure Dual-networks:
 - **Experimental – highly scalable / all-optical / technology oriented**
 - **Production for new applications and services**
- On-going wire area test-bed activities:

